

## Aluminum Nitride

## Flanged Termination

### Features:

- ◆ ALN material
- ◆ DC- 3 GHz performance
- ◆ 100 Watt power handling

### General Description:

The TA50R0-100-2X is a flange mounted termination capable of dissipating 100 Watts with a frequency from DC-3 GHz.

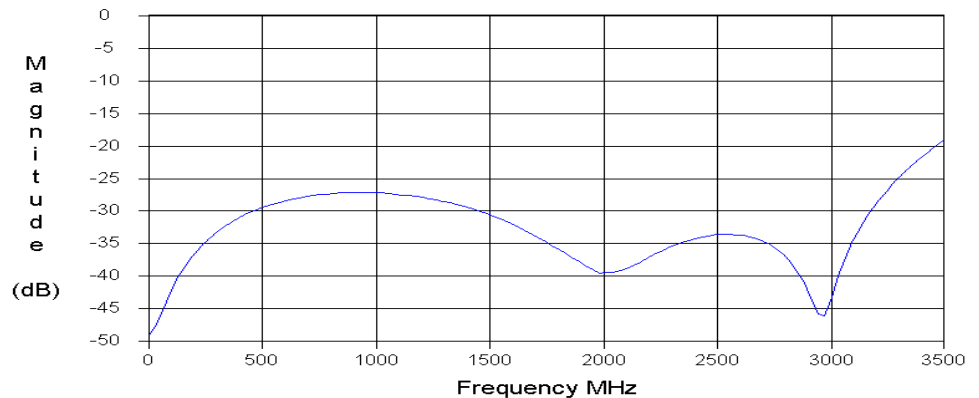
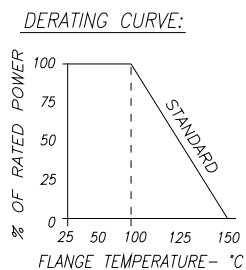
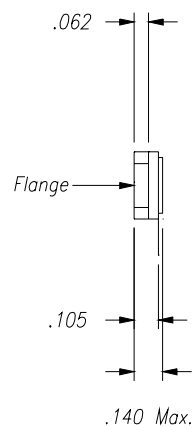
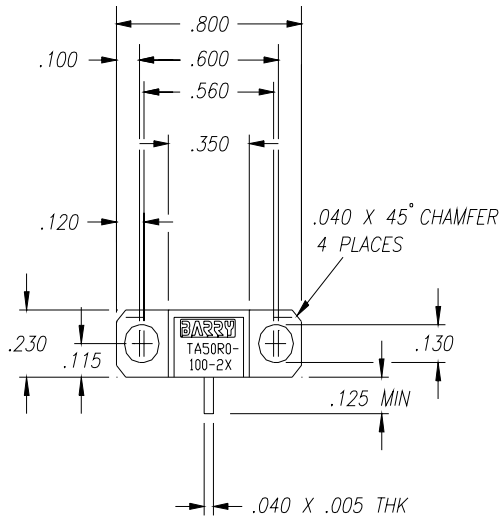

Parameter	Min.	Typ.	Max.	Units
Frequency Range	DC		3	GHz
Input Return Loss	28	35		dB
Power Dissipation			100	Watts
Flange Temperature			100	°C

\* Barry Industries reserves the right to change part number and or process without notification

Barry Industries, Inc., 60 Walton St., Attleboro, MA 02703 T: 508-226-3350 F: 508-226-3317 E-mail: sales@barryind.com

Barry Industries maintains an ISO 9001 Certified Quality Management System