

### T50R0-250-12E Features:

- TCE Matched, All Brazed Construction
- RoHS Compliant
- Customer Defined Testing Available
- Enhanced Mechanical Strength
- Covered Resistor Element
- ±5% Resistor Tolerance

### T50R0-250-12E Parameters:

Operating Frequency:	DC - 4GHz
Rated Power:	250W*
Return Loss (Typical)**:	18dB or Better (DC - 3GHz) 16dB or Better (>3GHz - 4GHz)
Impedance:	50Ω ±5%***
Resistor Construction:	Thick Film on BeO Attached with AuGe Braze
Flange Construction:	Copper Tungsten
Lead Construction:	Copper Attached with AuGe Braze
Operating Temperature:	-55 to +150°C



### T50R0-250-12E Power Derating Curve

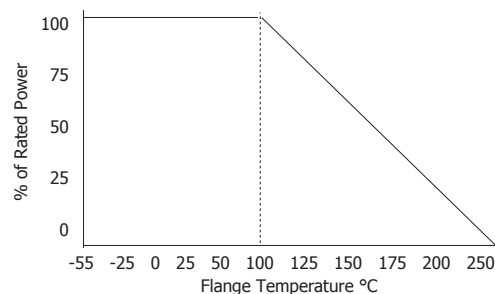

### T50R0-250-12E Dimensions:

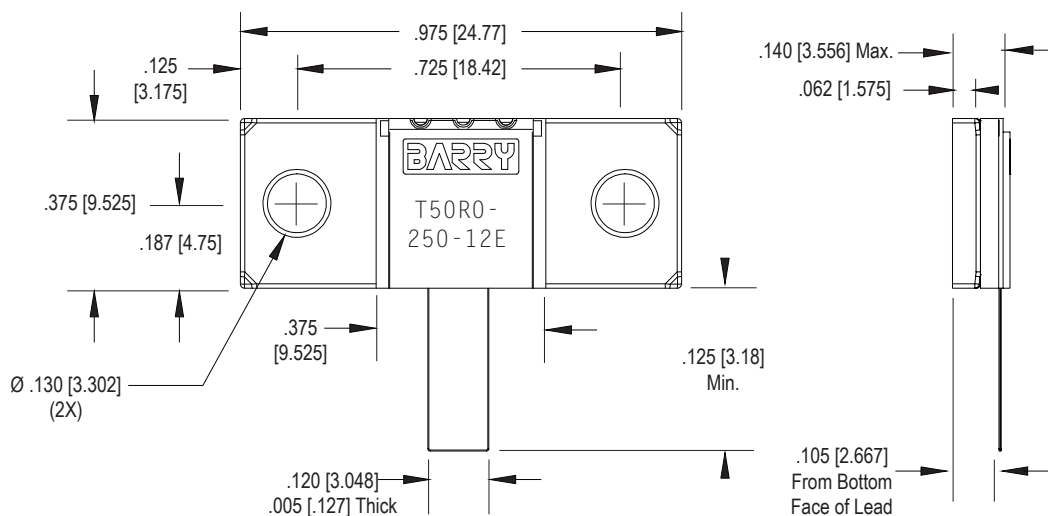

Dimensions in inches [mm]  
Tolerance is ± 0.010 [0.254]  
unless otherwise stated

\* Rating based on ≤100°C constant flange temperature  
\*\* In a matched, continuous 50Ω system with proper workmanship  
\*\*\* Other values and tolerances available. Contact factory.

### Ordering Information:

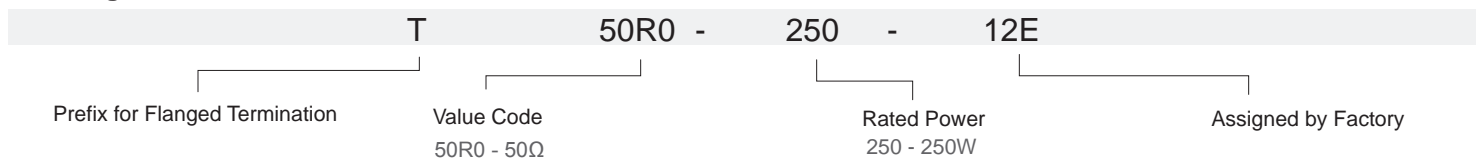

Barry Industries reserves the right to change part number and/or process without notification.



ORIG.	REV.	No.
OCT 1 2012	NOV 5 2014	B
PAGE 1 OF 2		

**T50R0-250-12E Reliability Data:**

Parameter:	Test Condition:	Results:
Short Time Overload	Apply 1.1x Rated Power for 5 Seconds.	≤ 2.0% Resistance Shift
Rated Load Life	Apply Full Power at 100°C ±2°C 90 Minutes on/ 30 Minutes off. Repeat for 1000 hours	≤ 2.0% Resistance Shift
Moisture Resistance	MIL-PRF-55342 para.4.8.9 95% RH, 25°C - 65°C	≤ 2.0% Resistance Shift
Resistance to Soldering Heat (Lead)	MIL-STD-202 Method 210 Test Condition "A"	≤ 2.0% Resistance Shift
Resistance to Soldering Heat (Assembly)	MIL-STD-202 Method 210 Test Condition "J"	≤ 2.0% Resistance Shift
Terminal Strength	MIL-STD-202 Method 211 Test Condition "A" 3lbs. Test Condition "B" 5 bends	No Significant Abnormality (Visual)
Solderability (Lead only)	MIL-STD-202 Method 208 Test C	>95% Covered
High Temperature Storage	125°C ±2°C for 500 Hours	1.) ≤ 2.0% Resistance Shift 2.) No Significant Abnormality (Visual)
Thermal Shock	-65°C to +150°C Each Cycle 30 Minutes for 500 Hours	1.) ≤ 2.0% Resistance Shift 2.) No Significant Abnormality (Visual)

For further detail on the advantages of using TCE Matched Copper-Tungsten flange mount devices from Barry Industries please refer to the Application Note 'Finite Element Analysis of a High Power Resistor'. This document can be found on the Barry Industries website: [www.barryind.com](http://www.barryind.com).

Barry Industries reserves the right to change part number and/or process without notification.

