

CHIP RESISTOR

Features:

- ◆ .15 Watt power dissipation
- ◆ 1/4 Wrap
- ◆ Compact construction



General Description:

The RK0603ZZ-XXXXWN-AA is a quarter wrap style chip resistor. Its compact size is ideal for miniature electronic components.

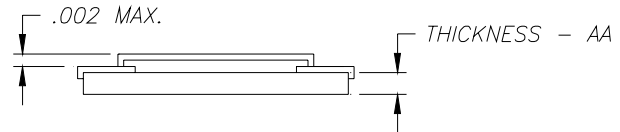
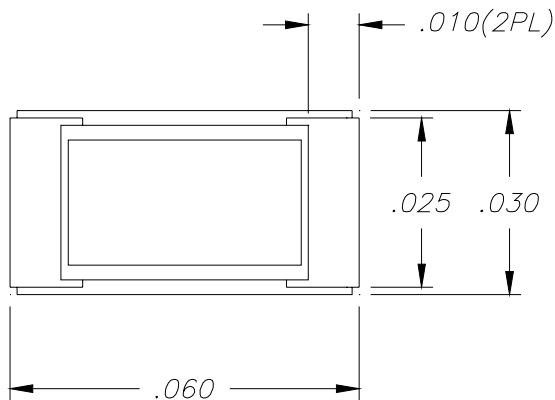

- All Dimensions in inches
- Tolerance $\pm .005$
- Full part number (RK0603ZZ-XXXXWN-AA)
- Example part number (RK0603CT-50R0JN-91)
- Dimensions apply before tinning

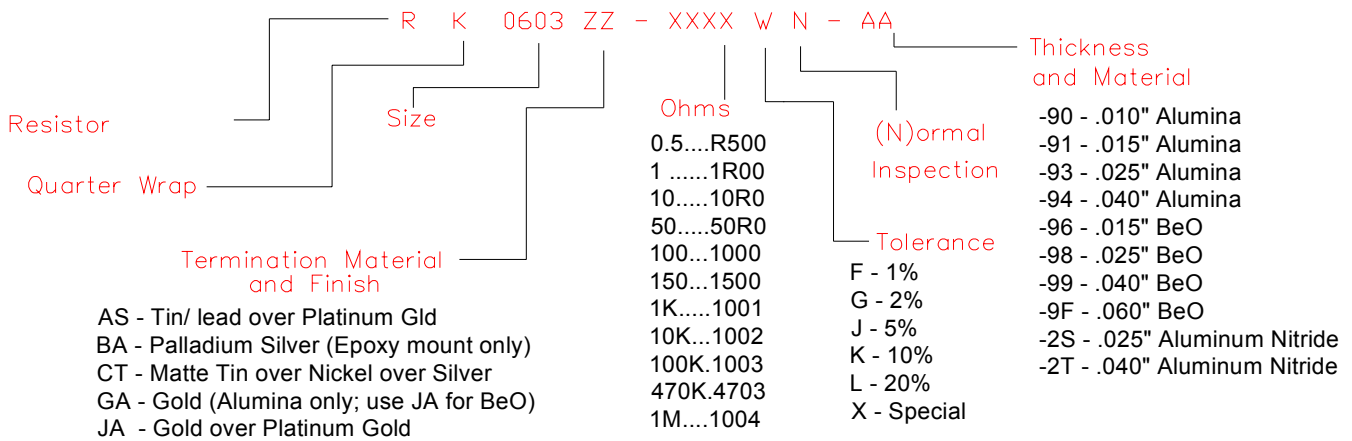

* Barry Industries reserves the right to change part number and or process without notification

Barry Industries, Inc., 60 Walton St., Attleboro, MA 02703 T: 508-226-3350 F: 508-226-3317 E-mail: sales@barryind.com

Barry Industries maintains an ISO 9001 Certified Quality Management System

Date	Rev.
02/13/06	-