

### TS0808ZZ-50R0JN-2S Features:

- Surface Mountable
- Solder or Epoxy Attachment
- RoHS Compliant or SnPb Available
- Customer Defined Testing Available
- ±5% Resistor Tolerance
- Tape and Reel or Waffle Pack Available (Standard is Bulk)

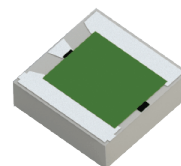

■ Actual Size

### TS0808ZZ-50R0JN-2S Parameters:

Operating Frequency:	DC - 44GHz
CW Input Power:	4W*
Peak Input Power (at 30% Duty Cycle):	20W for 10μ Seconds 10W for 50μ Seconds 5W for 1000μ Seconds
Return Loss (Typical)**:	20dB or Better
Impedance:	50Ω
Resistor Construction:	Thick Film on AIN
Operating Temperature:	-55 to +150°C

### TS0808ZZ-50R0JN-2S Power Derating Curve

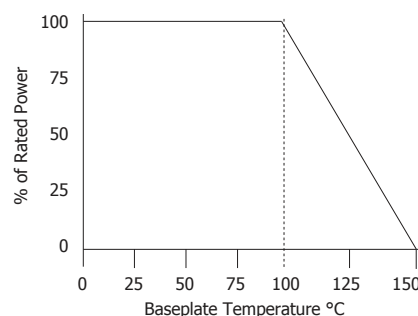

### TS0808ZZ-50R0JN-2S Dimensions:

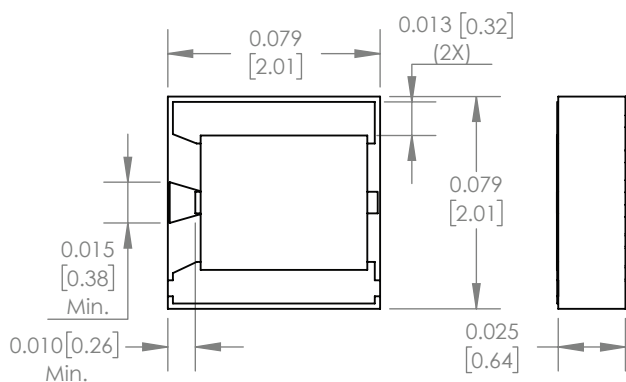

Back marked with impedance

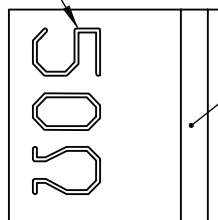

Alignment mark indicates input side

Dimensions in inches [mm]. Tolerance is ± 0.005 [0.254] unless otherwise stated

\* Rating based on ≤100°C constant baseplate temperature on recommended PCB land pattern w/ power applied  
 \*\* Performance based on board thicknesses of 8 to 10 mils with Cr= 3.2 to 3.6 in a matched, continuous 50Ω system with proper workmanship. Performance on other boards may vary. Contact factory with board properties for a custom simulation.

### TS0808ZZ-50R0JN-2S Ordering Information

TS	0808	ZZ	-	50R0	J	N	-	2S	UU
Prefix for Chip Termination w/ Single-Sided Terminals	Size 0808	Value Code 50R0 - 50Ω		Tolerance J - 5%	Normal Inspection Contact factory for additional options		Substrate 2S - 0.025" AIN	Packaging Blank - Bulk WP - Waffle Pack TRD - Tape and Reel	
Terminal Metallization	RoHS	Magnetic	Solder	Epoxy	Wirebond				
BA - Palladium Silver	Yes	No	No	Yes	No				
CB - SnPb over Nickel over Silver	No	Yes	Yes	No	No				
CT - 100% Matte Tin over Nickel over Silver	Yes	Yes	Yes	No	No				
GA - Gold	Yes	No	No	Yes	No				

Barry Industries reserves the right to change part number and/or process without notification.

### TS0808ZZ-50R0JN-2S Recommended Pad Layout & Mounting Configuration\*:

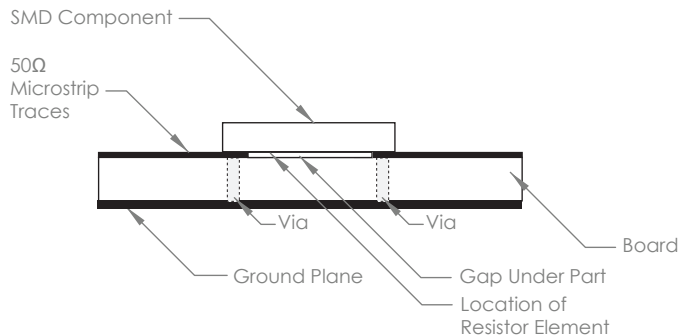
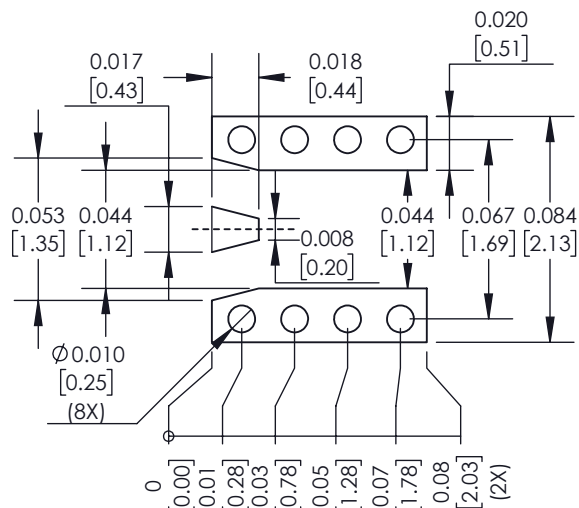

\* When mounting onto land pattern, alignment is critical for RF performance. Component must be positioned within  $\pm 0.002$  [0.051] of nominal center.

### TS0808ZZ-50R0JN-2S Reliability Specifications:

Parameter:	Test Condition:	Results:
Short Time Overload	Apply 1.1x Rated Power for 5 Seconds.	$\leq 5.0\%$ Resistance Shift
Rated Load Life	Apply 1/2 Power Under $40^{\circ}\text{C} \pm 2^{\circ}\text{C}$ 90 Minutes on/ 30 Minutes off. Repeat for 100 hours	$\leq 5.0\%$ Resistance Shift
Moisture Resistance	MIL-PRF-55342 para 4.8.9 95% RH, $25^{\circ}\text{C} - 65^{\circ}\text{C}$	$\leq 5.0\%$ Resistance Shift
High Temperature Storage	$125^{\circ}\text{C} \pm 2^{\circ}\text{C}$ for 500 Hours	1.) $\leq 5.0\%$ Resistance Shift 2.) No Significant Abnormality (Visual)
Thermal Shock	$-65^{\circ}\text{C}$ to $+150^{\circ}\text{C}$ 30 Minutes Dwell, 5 Cycles	1.) $\leq 5.0\%$ Resistance Shift 2.) No Significant Abnormality (Visual)

Barry Industries reserves the right to change part number and/or process without notification.