

### TA50R0-300-2X Features:

- Flange Mount
- RoHS Compliant
- Customer Defined Testing Available
- High Rated Power
- Covered Resistor Element
- ±5% Resistor Tolerance

### TA50R0-300-2X Parameters:

|                          |                      |
|--------------------------|----------------------|
| Operating Frequency:     | DC - 1.2GHz          |
| Rated Power:             | 300W*                |
| Return Loss (Typical)**: | 20dB or Better       |
| Impedance:               | 50Ω ±5%***           |
| Resistor Construction:   | Thick Film on AIN    |
| Flange Construction:     | Silver Plated Copper |
| Lead Construction:       | Silver Plated Copper |
| Operating Temperature:   | -55 to +150°C        |

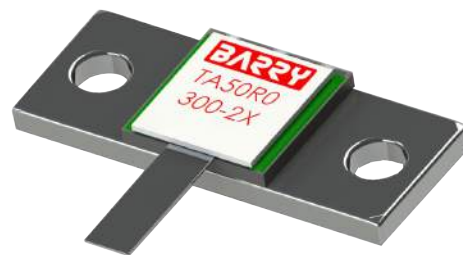

### TA50R0-300-2X Power Derating Curve

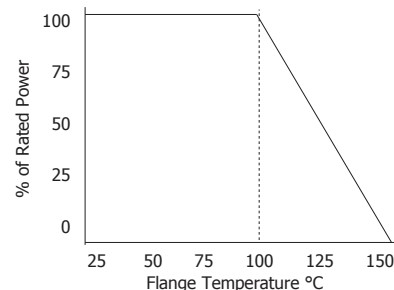

### TA50R0-300-2X Dimensions:

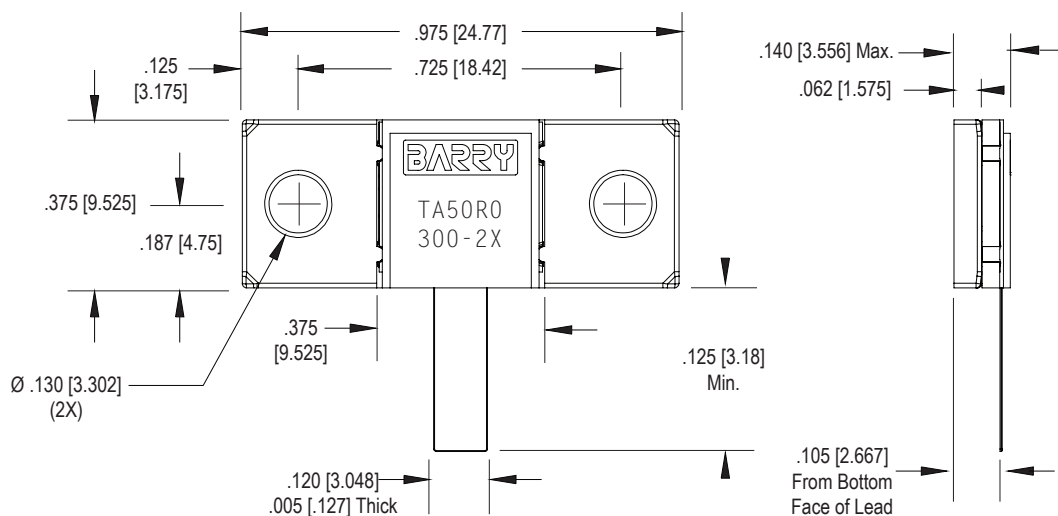

Dimensions in inches [mm]  
Tolerance is ± 0.010 [0.254]  
unless otherwise stated

\* Rating based on ≤100°C constant flange temperature  
\*\* In a matched, continuous 50Ω system with proper workmanship  
\*\*\* Other values and tolerances available. Contact factory.

### Ordering Information:

|   |                       |   |                        |   |                     |
|---|-----------------------|---|------------------------|---|---------------------|
| TA  | 50R0                  | - | 300                    | - | 2X                  |
| Prefix for Flanged Termination with AIN Substrate | Value Code 50R0 - 50Ω |   | Rated Power 300 - 300W |   | Assigned by Factory |

Barry Industries reserves the right to change part number and/or process without notification.



| ORIG.       | REV.        | No. |
|-------------|-------------|-----|
| NOV 13 2012 | OCT 23 2014 | A   |
| PAGE 1 OF 2 |             |     |

## TA50R0-300-2X Reliability Data:

| Parameter:                              | Test Condition:   | Results:   |
|---|---|--|
| Short Time Overload                     | Apply 1.1x Rated Power for 5 Seconds.   | ≤ 5.0% Resistance Shift  |
| Rated Load Life                         | Apply 1/2 Power Under 40°C ±2°C<br>90 Minutes on/ 30 Minutes off.<br>Repeat for 100 hours | ≤ 5.0% Resistance Shift  |
| Moisture Resistance                     | MIL-PRF-55342 para.4.8.9<br>95% RH, 25°C - 65°C   | ≤ 5.0% Resistance Shift  |
| Resistance to Soldering Heat (Lead)     | MIL-STD-202 Method 210<br>Test Condition "A"  | ≤ 5.0% Resistance Shift  |
| Resistance to Soldering Heat (Assembly) | MIL-STD-202 Method 210<br>Test Condition "J"  | ≤ 5.0% Resistance Shift  |
| Terminal Strength                       | MIL-STD-202 Method 211<br>Test Condition "A" 3lbs.<br>Test Condition "B" 5 bends          | No Significant Abnormality (Visual)                                    |
| Solderability (Lead only)               | MIL-STD-202 Method 208 Test C   | >95% Covered   |
| High Temperature Storage                | 125°C ±2°C for 500 Hours  | 1.) ≤ 5.0% Resistance Shift<br>2.) No Significant Abnormality (Visual) |
| Thermal Shock                           | -5°C to +150°C<br>30 Minutes Dwell, 5 Cycles  | 1.) ≤ 5.0% Resistance Shift<br>2.) No Significant Abnormality (Visual) |

Barry Industries reserves the right to change part number and/or process without notification.

