

### AA1000-250-17X Features:

- Flange Mount
- RoHS Compliant
- Customer Defined Testing Available
- High Rated Power
- Covered Resistive Element
- Symmetrical Design<sup>1</sup>

### AA1000-250-17X Parameters:

Nominal Attenuation:	10dB
Operating Frequency:	DC - 3GHz
Attenuation Tolerance:	±0.6dB
Return Loss (Typical)*:	21dB or Better (DC - 0.5GHz) 14dB or Better (>0.5GHz - 3GHz)
Rated Power**:	250W (at 70°C) 155W (at 100°C)
Impedance:	50Ω
Resistor Construction:	Thick Film on AIN
Flange Construction:	Silver Plated Copper
Lead Construction:	Silver Plated Copper
Operating Temperature:	-55 to +150°C



**AA1000-250-17X Power Derating Curve**

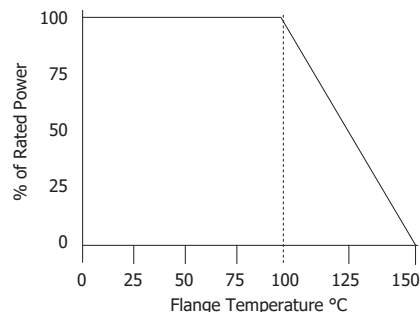

### AA1000-250-17X Dimensions:

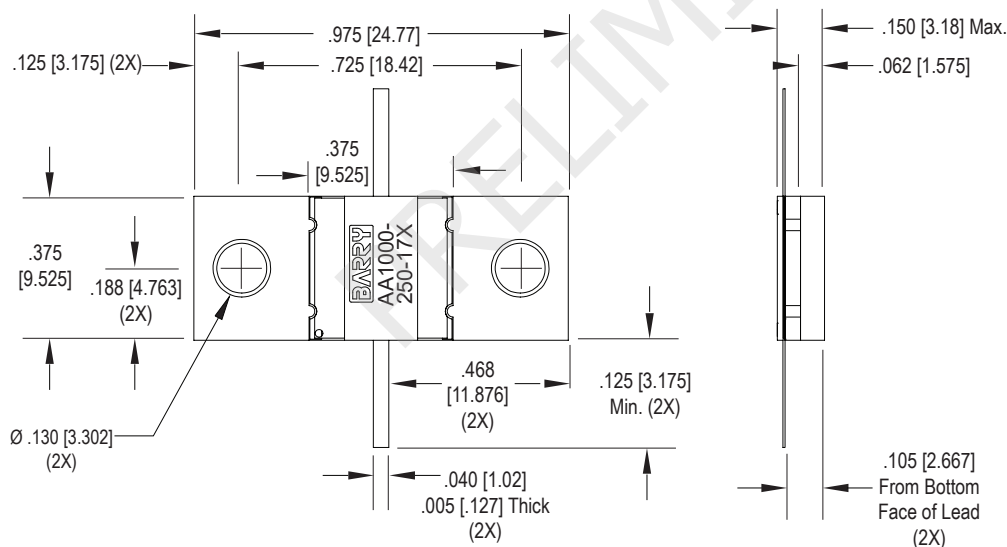

Dimensions in inches [mm]  
Tolerance is ± 0.010 [0.254]  
unless otherwise stated

<sup>1</sup> Can be mounted in either direction  
\* In a matched, continuous 50Ω system with proper workmanship  
\*\* Rating based on constant baseplate temperature

### Ordering Information:

AA	1000	-	250	-	17X
Prefix for Flanged Attenuator with AIN Substrate	Value Code 1000 - 10dB		Rated Power 250 - 250W		Assigned by Factory

Barry Industries reserves the right to change part number and/or process without notification.

**AA1000-250-17X Reliability Data:**

Parameter:	Test Condition:	Results:
Short Time Overload	Apply 1.1x Rated Power for 5 Seconds.	≤ 5.0% Resistance Shift
Rated Load Life	Apply 1/2 Power Under 40°C ±2°C 90 Minutes on/ 30 Minutes off. Repeat for 100 hours	≤ 5.0% Resistance Shift
Moisture Resistance	MIL-PRF-55342 para.4.8.9 95% RH, 25°C - 65°C	≤ 5.0% Resistance Shift
Resistance to Soldering Heat (Lead)	MIL-STD-202 Method 210 Test Condition "A"	≤ 5.0% Resistance Shift
Resistance to Soldering Heat (Assembly)	MIL-STD-202 Method 210 Test Condition "J"	≤ 5.0% Resistance Shift
Terminal Strength	MIL-STD-202 Method 211 Test Condition "A" 3lbs. Test Condition "B" 5 bends	No Significant Abnormality (Visual)
Solderability (Lead only)	MIL-STD-202 Method 208 Test C	>95% Covered
High Temperature Storage	125°C ±2°C for 500 Hours	1.) ≤ 5.0% Resistance Shift 2.) No Significant Abnormality (Visual)
Thermal Shock	-5°C to +150°C 30 Minutes Dwell, 5 Cycles	1.) ≤ 5.0% Resistance Shift 2.) No Significant Abnormality (Visual)

Barry Industries reserves the right to change part number and/or process without notification.