

ATC2525CT-3000JN-99 Features:

- PI Configuration
- RoHS Compliant
- Solderable Terminals
- Customer Defined Testing Available
- Symmetrical Design
- Tape & Reel or Waffle Pack Available (Standard is bulk)

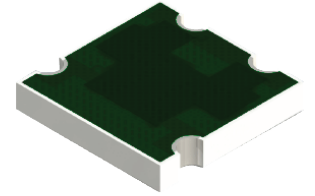

ATC2525CT-3000JN-99 Parameters:

Nominal Attenuation:	30dB	
Operating Frequency*:	DC - 2.5GHz	
Attenuation Tolerance*:	28dB Min., 30.5dB Max.	(DC - 0.7 GHz)
Input Power**:	13W	
VSWR Max.*:	1.2	(DC - 1GHz)
	1.4	(>1 - 1.6GHz)
	1.6	(>1.6 - 2GHz)
	1.85	(>2 - 2.5GHz)
Impedance:	50Ω	(47.5Ω Min., 52.5Ω Max.)
Construction:	Thick Film on BeO	
Operating Temperature:	-55 to +150°C	
Mounting Pad to Film Thermal Resistance is 11.4°C/Watt, Max. Film Temperature is 250°C		

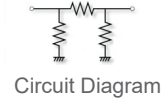

ATC2525CT-3000JN-99 Power Derating Curve

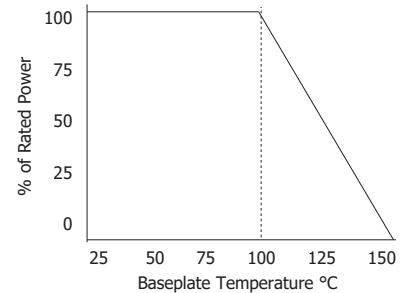

Can be mounted in either direction
 * Applies to 12 mil Rogers 4003 (Er=3.55). See page 2 for other circuit boards.
 ** Rating based on 100°C mounting pads

ATC2525CT-3000JN-99 Dimensions:

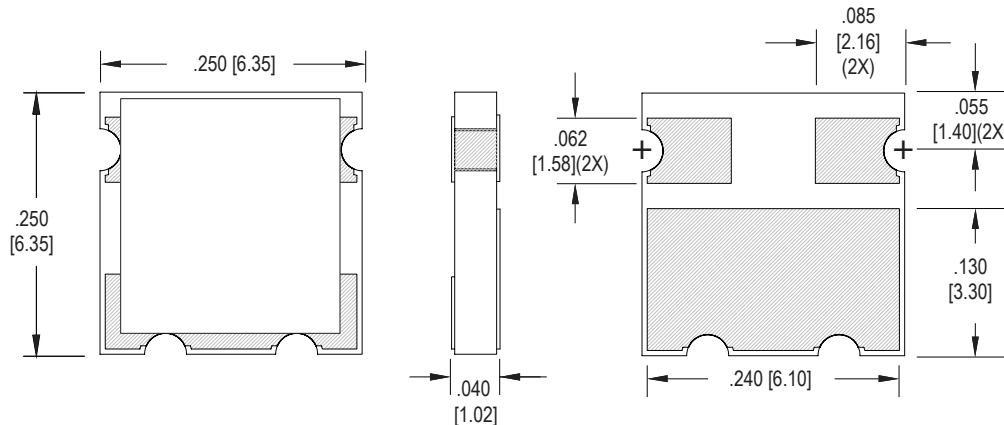

Dimensions in inches [mm]
 Tolerance is ± 0.005 [0.13]
 unless otherwise stated

Ordering Information:

ATC	2525	CT	-	3000	JN	-	99	UU
Prefix for 3 Sided Wraparound Attenuator w/ Castellations	Size 2525			Value Code 3000 - 30dB	Normal Inspection Contact factory for additional options		Substrate 99 - 0.040" BeO	Packaging Blank - Bulk TR - Tape and Reel WP - Waffle Pack
Terminal Metallization		RoHS	Magnetic	Solder	Epoxy	Wirebond		
CT - 100% Matte Tin over Nickel over Silver		Yes	Yes	Yes	No	No		

Barry Industries reserves the right to change part number and/or process without notification.

ATC2525CT-3000JN-99 VSWR:

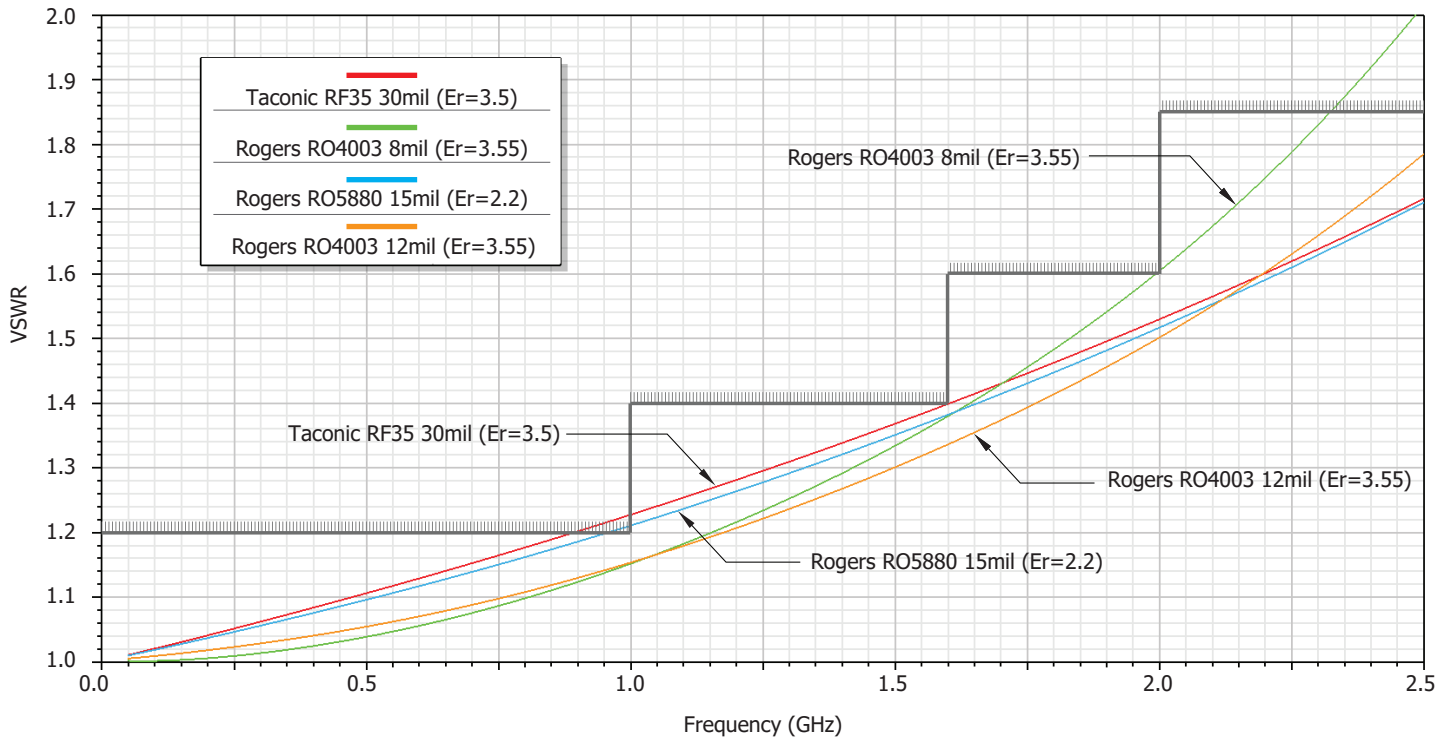

ATC2525CT-3000JN-99 Attenuation Accuracy:

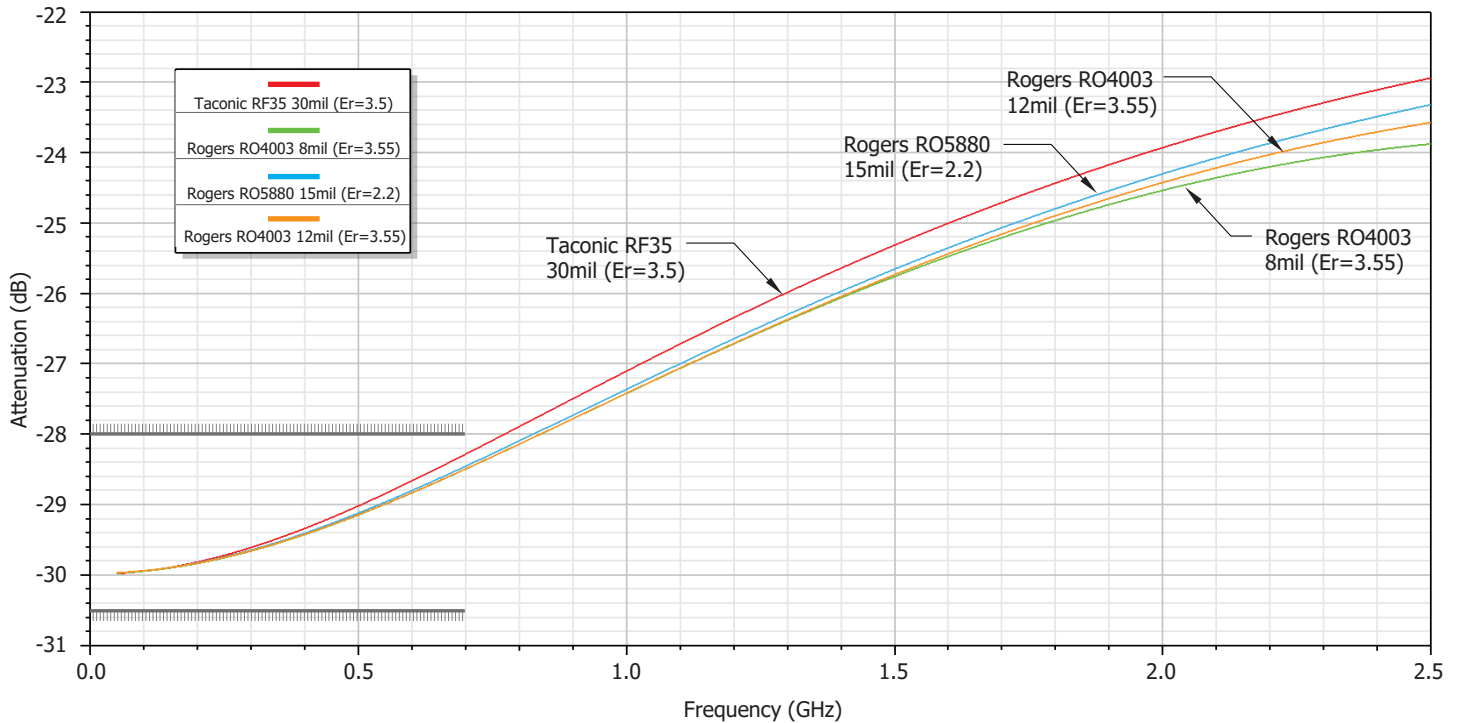

Barry Industries reserves the right to change part number and/or process without notification.

ATC2525CT-3000JN-99 Reliability Specifications:

Parameter:	Test Condition:	Results:
Short Time Overload	Apply 1.1x Rated Power for 5 Seconds.	≤ 5.0% Resistance Shift
Rated Load Life	Apply 1/2 Power Under 40°C ±2°C 90 Minutes on/ 30 Minutes off. Repeat for 100 hours	≤ 5.0% Resistance Shift
Moisture Resistance	MIL-PRF-55342 para 4.8.9 95% RH, 25°C - 65°C	≤ 5.0% Resistance Shift
Resistance to Soldering Heat	MIL-STD-202 Method 210 and MIL-PRF-55342 Para 4.8.8.1	≤ 5.0% Resistance Shift
Solderability	MIL-PRF-55342 Para 4.8.12	>95% Covered
High Temperature Storage	125°C ±2°C for 500 Hours	1.) ≤ 5.0% Resistance Shift 2.) No Significant Abnormality (Visual)
Thermal Shock	-65°C to +150°C 30 Minutes Dwell, 5 Cycles	1.) ≤ 5.0% Resistance Shift 2.) No Significant Abnormality (Visual)

Barry Industries reserves the right to change part number and/or process without notification.