

ALUMINUM NITRIDE 30 dB CHIP ATTENUATOR

Features:

- ◆ ALN material
- ◆ 100 Watt Input Power
- ◆ Solder Mountable
- ◆ CT - Matte Tin over Nickel over Silver

General Description:

The AVC2335CT-3000GN-2T-26 is a 30 dB Aluminum Nitride chip attenuator with a frequency range from DC - 3.6 GHz and an input power of 100 Watts while maintaining a mounting surface temperature of 100°C max.

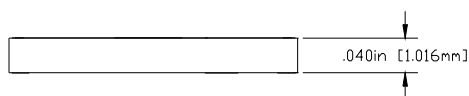
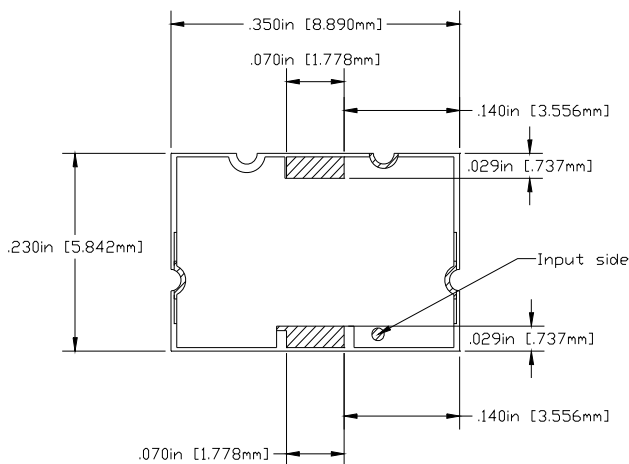

Dimensions in inches [mm]
Tolerance ± .010 [.254]
unless otherwise stated

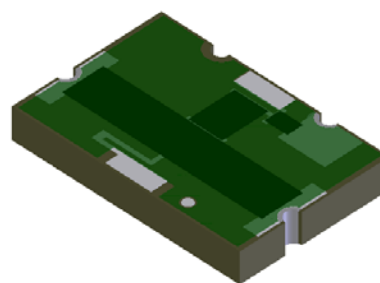

DERATING CURVE:

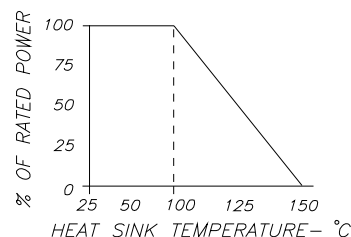

Parameter	Min.	Typ.	Max.	Units
Frequency Range	DC		3.6	GHz
Attenuation	29	30	31	dB
Input Return Loss	DC - 3.0 GHz 3.0 - 3.6 GHz	20 16.50		dB
Output Return Loss	DC - 3.0 GHz 3.0 - 3.6 GHz	20 16.50		dB
Input Power			100	WATTS
Reverse Power (output)			2	WATTS
Mounting Surface Temperature			100	°C

Barry Industries reserves the right to change part number and or process without notification.

Barry Industries, Inc., 60 Walton St., Attleboro, MA 02703 T: 508-226-3350 F: 508-226-3317 E-mail: sales@barryind.com

Barry Industries maintains an ISO 9001 Certified Quality Management System

Origination Date	Revision Date	Rev.
06/25/07	10/08/08	A