

## Aluminum Nitride

## FLANGED ATTENUATOR

### Features:

- ◆ AIN Material
- ◆ DC - 4 GHz Performance
- ◆ 50 Watt Input Power
- ◆ Flange Mount

### General Description:

The AA1000-50-1X is a flanged 10 dB Aluminum Nitride attenuator. It has an input power rating of 50 watts, while maintaining a constant flange temperature of 100°C. It offers a frequency range from DC to 4 GHz.

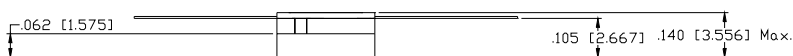
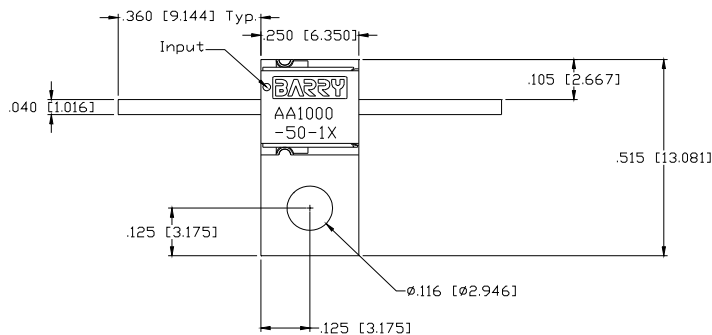

Dimensions in inches [mm]  
Tolerance  $\pm$  .010 [.254]  
unless otherwise stated

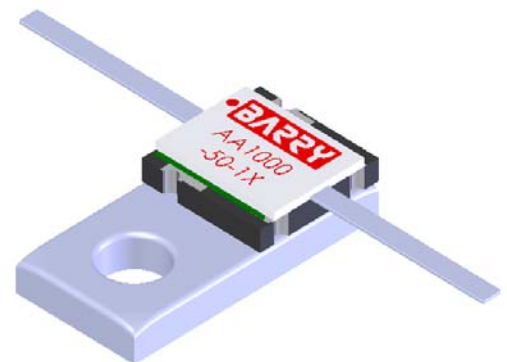

### DERATING CURVE:

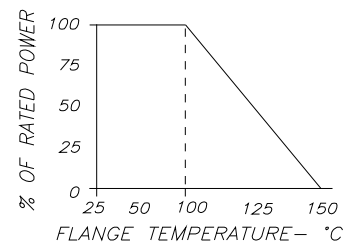

Parameter	Min.	Typ.	Max.	Units
Frequency Range	DC		4	GHz
Input Return Loss	17			dB
Output Return Loss	17			dB
Input Power			50	Watts
Flange Temperature			100	°C
Attenuation Flatness	9	10	11	dB

Barry Industries reserves the right to change part number and or process without notification.

Barry Industries, Inc., 60 Walton St., Attleboro, MA 02703 T: 508-226-3350 F: 508-226-3317 E-mail: sales@barryind.com

Barry Industries maintains an ISO 9001 Certified Quality Management System

Origination Date	Revision Date	Rev.
11/10/10	11/10/10	-