

Revisions	ECO #	
	Approved	
	Date	
	Description	
Rev		

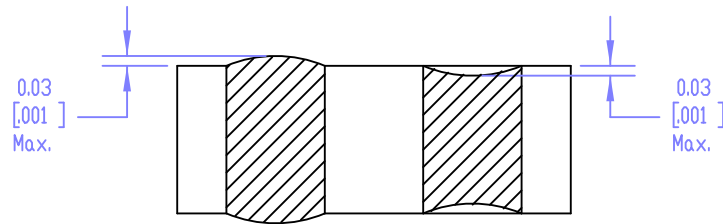

Via Planarity (not to scale)

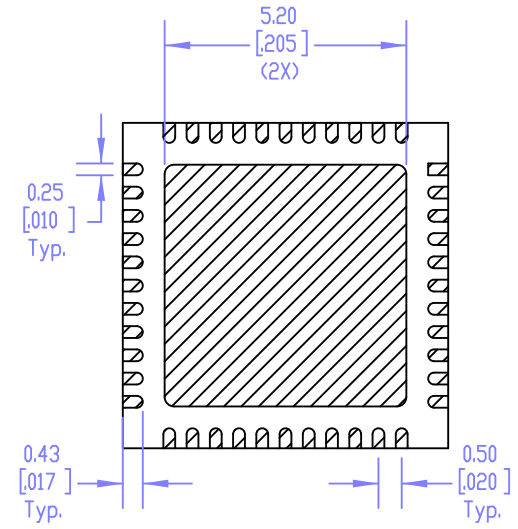
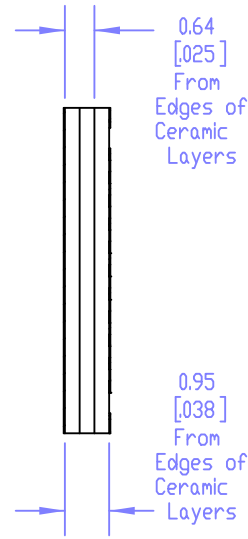
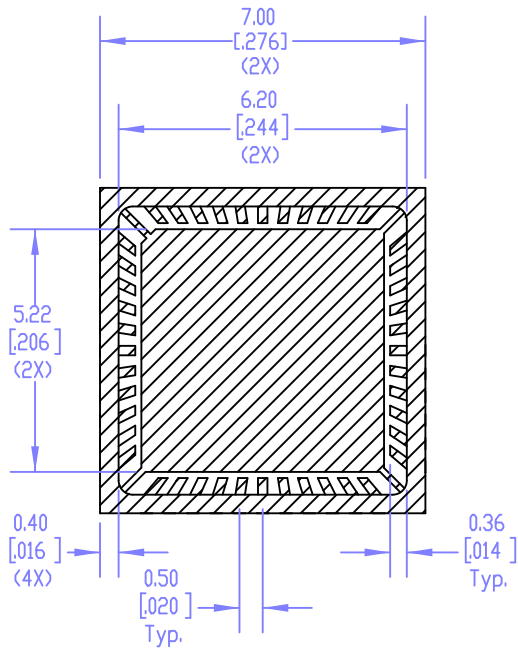
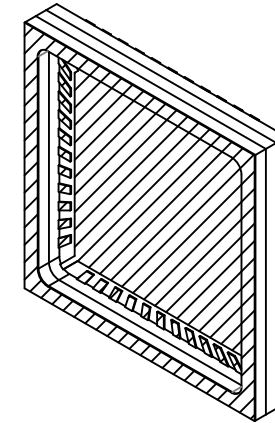

Drawn R. HUOT	Date NOV 10 2016
Engineering	Date
Q.A.	Date
Manufacturing	Date
Released	Date

UNLESS OTHERWISE SPECIFIED: DIMENSIONS ARE IN MILLIMETERS.	
TOLERANCES ON DECIMALS	ON ANGLES
.X ± .25	± .5°
.XX ± .10	
.XXX ± .050	
.XXXX ± .0100	
Material Alumina	CODE IDENT NO. 6P825
Finish	

BARRY
60 WALTON ST.
ATTLEBORO, MA. 02703
(508) 226-3350
www.barryind.com

Scale 6:1
Drawing Size A

Title 7mm - 44 Pin QFN - Grounded Seal Ring	
Drawing No. QFN-7744-0521	Revision B
Used On	Qty.
Sheet 1 of 1	